

Easi Frame

Single Sided

The Easi Frame is an aluminium frame consisting of aluminium lengths, L-shaped corner brackets, straight brackets (where needed) and a fabric skin with silicone edge. This guide will show you the steps needed to construct the frame and also the correct technique for inserting the fabric skin.

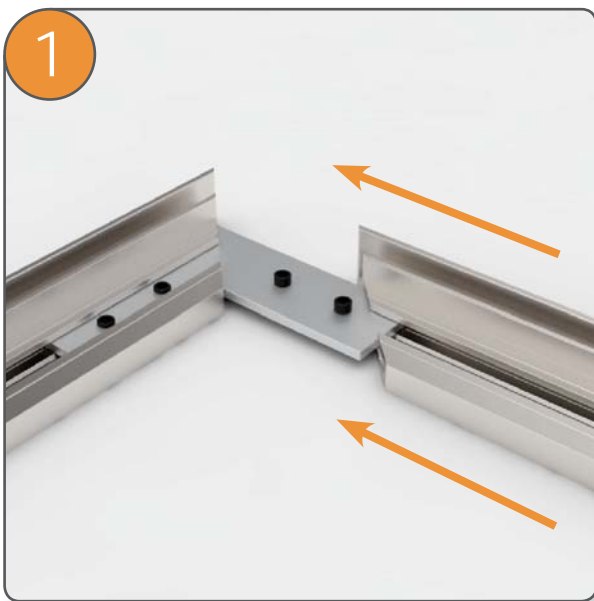

Step 1

Slide the L-shaped corner bracket all the way into the slot at the end of the aluminium frame piece. Then slide the next aluminium frame piece onto the L-shaped corner bracket.

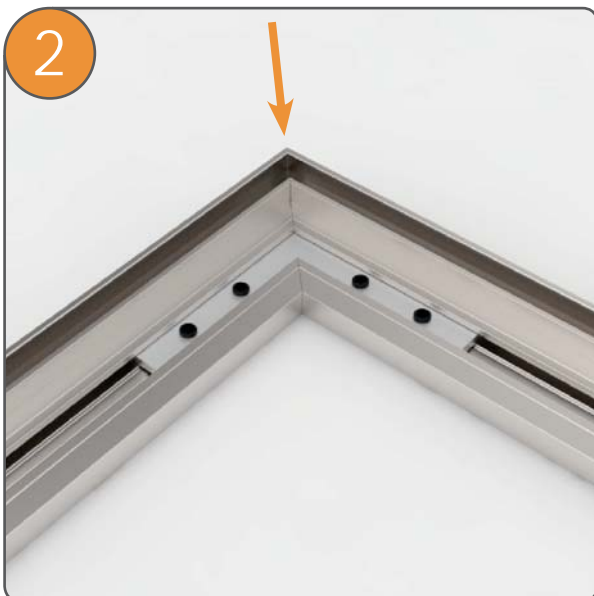

Step 2

Make sure that the two frame pieces meet at a point with no gaps between them. Repeat this step for all 4 corners.

Note: Do not tighten the corner bracket screws yet. This can make it difficult to get the other sides in.

Easi Frame Single Sided



Step 3

Once you have all of the corner brackets in place tighten them with an Alan Key (supplied).

Note: Be sure not to overtighten the screws as this may cause damage.

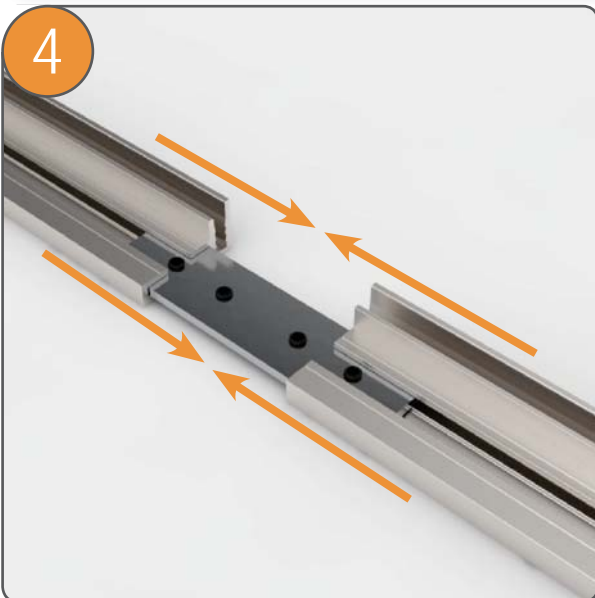

Step 4 (not required on all frames)

Slide the straight bracket into the end of the aluminium frame. Then slide the other piece of frame onto the bracket. Before tightening the screws, make sure that the bracket is evenly centred.



Step 5

Some frames may be supplied with holes predrilled for wall mounting.

NOTE: Failing to screw the frame to the wall using ALL provided holes may cause the frame to sag after installing the fabric skin.

Other frames may be supplied with wall mount brackets. Simply attach the bracket to the wall using two screws.

Easi Frame Single Sided



Step 6 (Inserting the fabric skin)

To install the fabric skin correctly start by inserting the silicone edge with fabric into the four corners. Then firmly insert the middle sections before inserting the remaining fabric. Please refer to the diagram below.

